

## INSTALLATION AND REMOVAL INSTRUCTIONS FOR B-LOC® KEYLESS BUSHING SERIES B800

**B-LOC®** Keyless Bushings provide a high capacity, zero-backlash shaft/hub or coupling connection by means of a mechanical interference fit. Please follow these **INSTALLATION AND REMOVAL INSTRUCTIONS** carefully to ensure proper performance of this **B-LOC®** unit.

### ⓘ WARNING ⓘ

When installing or removing **B-LOC®** products, always adhere to the following safety standards:

1. Be sure that all power switches are locked out before installing or removing **B-LOC®** products.
2. Eye protection is required when installing or removing **B-LOC®** products - please wear safety glasses and protective clothing.

### INSTALLATION

(Refer to Figure 1)

**B-LOC®** Keyless Bushings are supplied lightly oiled and ready for installation. When reinstalling a used unit, make sure that all slits are aligned. The frictional torque capacity of these devices is based on a coefficient of friction of 0.12 for lightly oiled screw, taper, shaft and bore contact areas.

**Therefore, it is important not to use Molybdenum Disulfide (e.g., Molykote, Never-Seeze or similar lubricants) in any Keyless Bushing installation.**

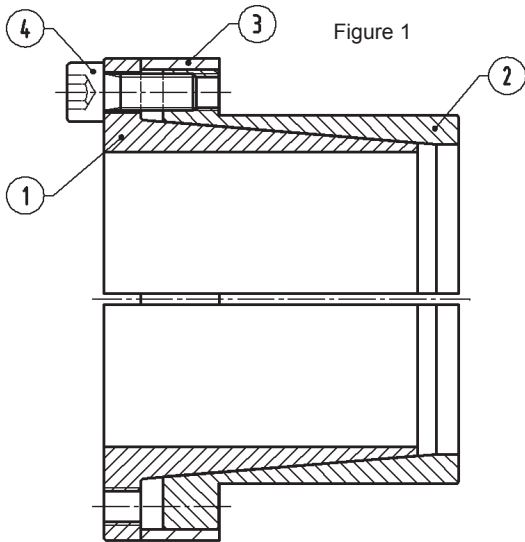

1. Make sure that locking screw, taper, shaft and bore contact areas are clean and lightly oiled and that all collar slits are aligned.
2. Loosen all locking screws by a minimum of two (2) turns and transfer at least three (3) screws into push-off threads in order to keep Parts 1 and 2 separated during assembly (see Figure 2).
3. After inserting Keyless Bushing into hub bore, relocate locking screws used for separating Parts 1 and 2.
4. Hand tighten locking screws and confirm that collar Item 1 is parallel with face of part to be attached to shaft, and that spacer sleeve fully contacts both part and Keyless Bushing face.
5. Use torque wrench and set it approximately 5% higher than specified tightening torque  $M_a$ . Tighten locking screws in either a clockwise or counterclockwise sequence (it is not necessary to tighten in a diametrically opposite pattern), using only 1/4 (i.e., 90°) turns for several passes until 1/4 turns can no longer be achieved.
6. Continue to apply overtorque for 1 to 2 more passes. This is required to compensate for a system-related relaxation of locking screws since tightening of a given screw will always relax adjacent screws. Without overtorquing, an infinite number of passes would be needed to reach specified tightening torque.
7. Reset torque wrench to specified torque ( $M_a$ ) and check all locking screws. No screw should turn at this point, otherwise repeat Step 6 for 1 or 2 more passes. It is not necessary to re-check tightening torque after equipment has been in operation.

**NOTE:** In applications subject to extreme corrosion, the slits in all collars should be sealed with a suitable caulking compound or equivalent. Likewise, push-off threads should be protected from corrosion.

## INSTALLATION OF B-LOC® KEYLESS BUSHING OVER SHAFT KEYWAYS

The Keyless Bushing should be positioned so that slits in Keyless Bushing collars that contact the shaft are located approximately opposite the keyway. In addition, a locking screw should be centered directly over the keyway.

When tightening locking screws, it is important to follow the installation procedure outlined above, which specifies equal 1/4 turns of each locking screw. Failure to follow these instructions could result in excessive tightening of the screw over the keyway, possibly causing permanent deformation of the Keyless Bushing collars. Even after 1/4 turns can no longer be achieved, it is important to continue to use equal turning angles for every screw until the specified tightening torque is reached.

### REMOVAL

(Refer to Figure 2)

**Prior to initiating the following removal procedure, check to ensure that no torque or thrust loads are acting on the Keyless Bushing, shaft or any mounted components.**

**IMPORTANT!** Make sure ends of locking screws used for removal are ground flat and are slightly chamfered to prevent damage to screw and collar threads during push-off.

1. Check to ensure that axial movement of collars - necessary for release of connection - is not restricted. Likewise, ensure that push-off threads are in good condition.
2. Loosen locking screws in several stages by using approx. 1/4 turns, following either a clockwise or counterclockwise sequence. Transfer required number of screws into all push-off threads of clamp collar Item 1 (see Figure 2).
3. Release connection by evenly tightening all push-off screws (not exceeding 1/4 turns) in either a clockwise or counterclockwise sequence.

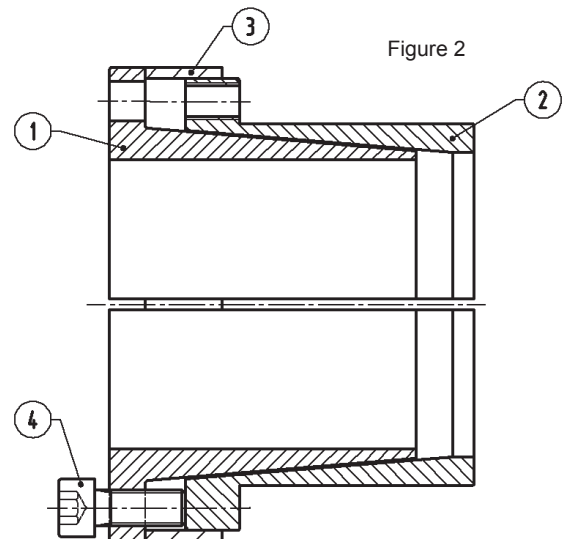

### LOCKING SCREW SIZES AND SPECIFIED TIGHTENING TORQUE $M_a$ B800 KEYLESS BUSHING

Metric Series	Inch Series	Tightening Torque $M_a$ (ft-lbs)	Screw Size	Hex Key Size (mm)
6 x 14 to 14 x 23	1/4 to 1/2	3.55	M 4	3
15 x 24 to 42 x 55	5/8 to 1-5/8	12	M 6	5
45 x 59 to 65 x 84	1-11/16 to 2-1/2	30	M 8	6
70 x 90 to 95 x 120	2-5/8 to 3-3/4	60	M 10	8
100 x 125 to 130 x 165	3-7/8 to 4-15/16	105	M 12	10